

Suitability

For use on sites where unstable/wet/granular soils overlie stable dry cohesive soils such as clay or chalk.

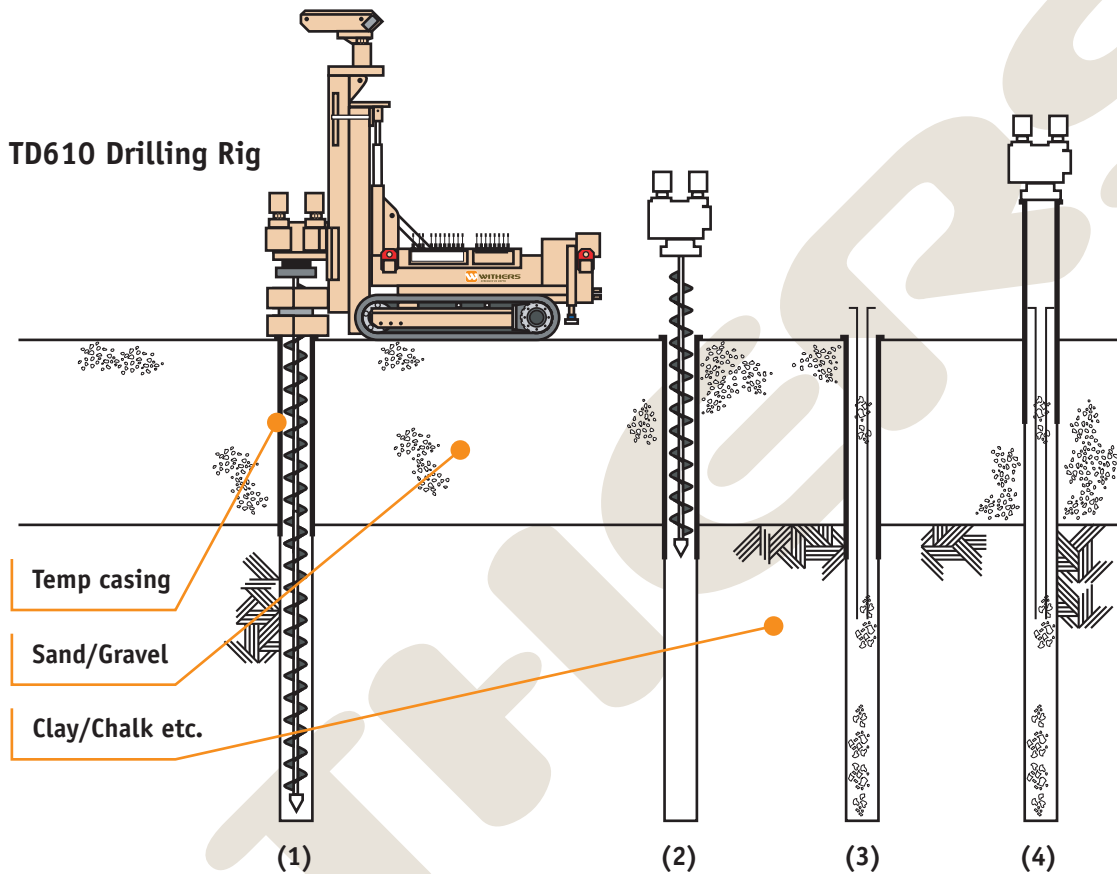

Method

1. Temporary casing is screwed in to required depth and then pile augered to designed length.
2. Extract auger and remove spoil arisings.
3. Place concrete/grout and reinforcement.
4. Extract temporary casing.

Diameters

- 100, 150, 200, 250, 300, 350 & 450mm

Equipment

Medium sized track mounted rigs (up to 9T) using a range of segmental augers.